

Series 10-/11-/12- 21-/22-CXS

Dual rod cylinder
 $\varnothing 6, \varnothing 10, \varnothing 15, \varnothing 20, \varnothing 25, \varnothing 32$

How to Order

● Clean series

10	Relief type	CXSM, CXSL
11	Vacuum suction type	CXSM, CXSL
12	Relief type (with specially treated sliding parts)	CXSL

● Dual rod cylinder

10 - CXS M 15 - 30 - Y59A

21 - CXS L 15 - 30 - Y59A

● Bearing type

L	Ball bushing bearing
M	Slide bearing

● Bore size (mm)

Symbol	Type	Bore size
Nil	M5 x 0.8	$\varnothing 6$ to $\varnothing 20$
	Rc	
TN	NPT	$\varnothing 25, \varnothing 32$
TF	G	

● Port type

● Number of auto switches

Nil	2 pcs.
S	1 pc.
n	n pcs.

● Type of auto switch

Reed switch	Z73
Solid state switch	Y59A, Y59B

● Copper, fluorine and silicone-free + low particle generation

21	Relief type	CXSL
22	Vacuum suction type	CXSL

● Cylinder stroke (mm)

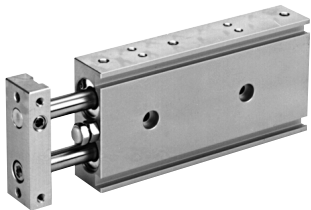

Model

Model	Bore size (mm)	Port size	Lubrication	Action	Standard stroke (mm)	Auto switch mounting	Cushion	
							Rubber	Air
Vacuum suction type	11-/22-CXS□6	6	Non-lube	Double acting single rod	10, 20, 30, 40, 50	○	○ (Both sides)	—
	11-/22-CXS□10	10						
	11-/22-CXS□15	15						
	11-/22-CXS□20	20						
	11-/22-CXS□25	25						
	11-/22-CXS□32	32						
Relief type	10-/12-/21-CXS□6	6	M5 x 0.8	Double acting single rod	10, 20, 30, 40, 50	○	○ (Both sides)	—
	10-/12-/21-CXS□10	10						
	10-/12-/21-CXS□15	15						
	10-/12-/21-CXS□20	20						
	10-/12-/21-CXS□25	25						
	10-/12-/21-CXS□32	32						

Specifications

Item	Bore size (mm)		
	6	10/15	20/25/32
Proof pressure	1.05 MPa		
Max. operating pressure	0.7 MPa		
Min. operating pressure	0.15 MPa	0.1 MPa	0.05 MPa
Ambient and fluid temperature	-10 to 60°C (With no condensation)		
Piston speed	30 to 400 mm/s		
Stroke adjustable range	0 to -5mm compared to the standard stroke		
Bearing type	Ball bushing bearing/Slide bearing		
Grease	10-/11-/12-: Fluorine grease 21-/22-: Lithium soap base grease		
Particle generation grade (Refer to front matter pages 13 to 22 for details.)	10-/12-: Grade 2, 21-: Grade 3 11-/22-: Grade 1		

Suction flow rate of vacuum suction type (Reference values)

Size	Suction flow rate L/min (ANR)
6	2
10	5
15	10
20/25	15
32	20

Auto switch specifications (Refer to Best Pneumatics catalog for detailed specifications and auto switches not in the following table.)

Style	Auto switch part no.	Load voltage	Load current range	Indicator light	Application
Reed switch	D-Z73	24 VDC, 100 VAC	5 to 40mA, 5 to 20mA	○	Relay, PLC
Solid state switch	2-wire type D-Y59B	24 VDC (10 to 28V)	5 to 40mA	○	24 VDC Relay, PLC
	3-wire type D-Y59A	28 VDC or less	40mA or less	○	IC circuit, Relay, PLC

Refer to applicable auto switch list — Page 182.

PLC: Programmable Logic Controller

Auto switches / Proper mounting position for stroke end detection

Electrical entry direction: Inward

Electrical entry direction: Outward

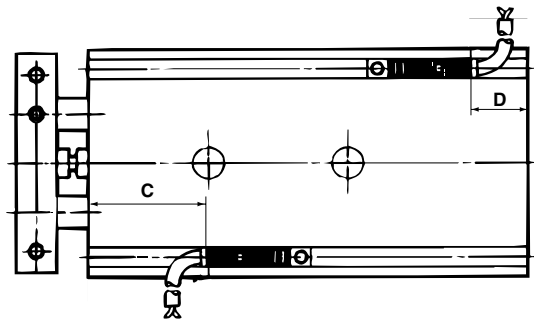
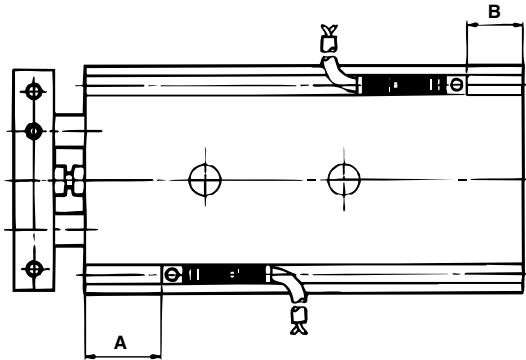

(mm)

Bore size	A	B	D-Z73		D-Y59A, D-Y59B	
			C	D	C	D
6	20.5	4.5	15	-1	16.5	0.5
10	27	8	21.5	2.5	23	4
15	38	4.5	32.5	-1	34	0.5
20	50	7	44.5	1.5	46	3
25	50.5	8.5	45	3.5	46.5	5
32	60	9	54.5	3.5	56	5

Note 1) The above mentioned values are indicated as a guide for auto switch mounting position for stroke end detection. When actually mounting an auto switch, adjust the position after confirming the operating state of the auto switch.

Note 2) Lead wire entry is inward when the product is shipped.

Dual rod cylinder ^{10-/11-}₂₂₋**CXS**□/¹²⁻₂₁₋**CXSL**

Basic style / ^{10-/11-}₂₂₋**CXS**□15, ¹²⁻₂₁₋**CXSL**15

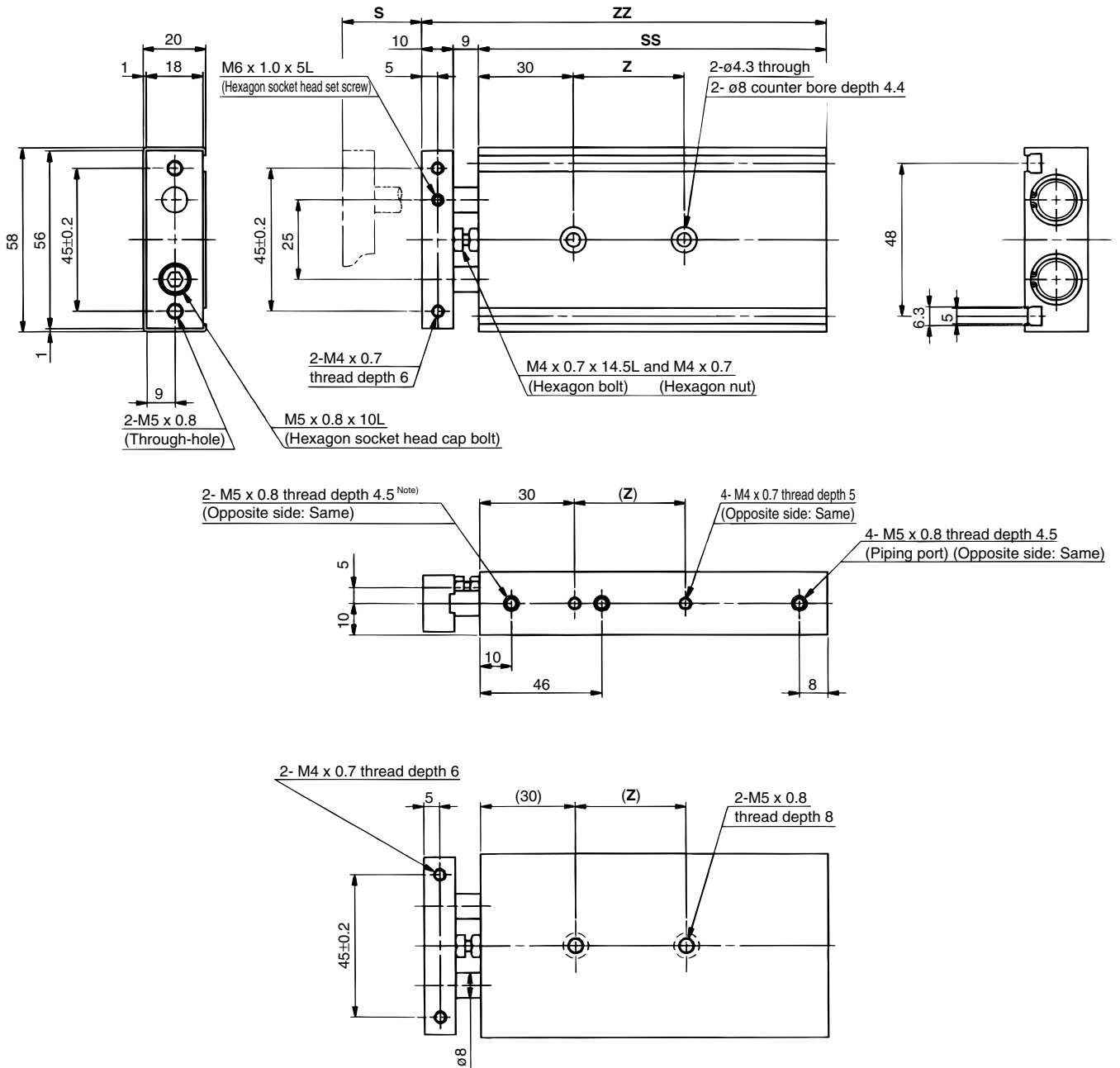

Note) 11-, 22- : Vacuum suction port Vacuum air from 2 ports on both sides. 10-/12-, 21- : Exhaust port Exhaust air from a port on one side. The port on the piston rod B side for 10-/12-, 21- is plugged since unlike the vacuum, it is not necessary to exhaust from 2 ports.

(mm)

Model	S	SS	ZZ	Z
^{10-/11-} _{21-/22-} CXS □15-10	10	77.5	96.5	25
^{10-/11-} _{21-/22-} CXS □15-20	20	87.5	106.5	25
^{10-/11-} _{21-/22-} CXS □15-30	30	97.5	116.5	35
^{10-/11-} _{21-/22-} CXS □15-40	40	107.5	126.5	35
^{10-/11-} _{21-/22-} CXS □15-50	50	117.5	136.5	45

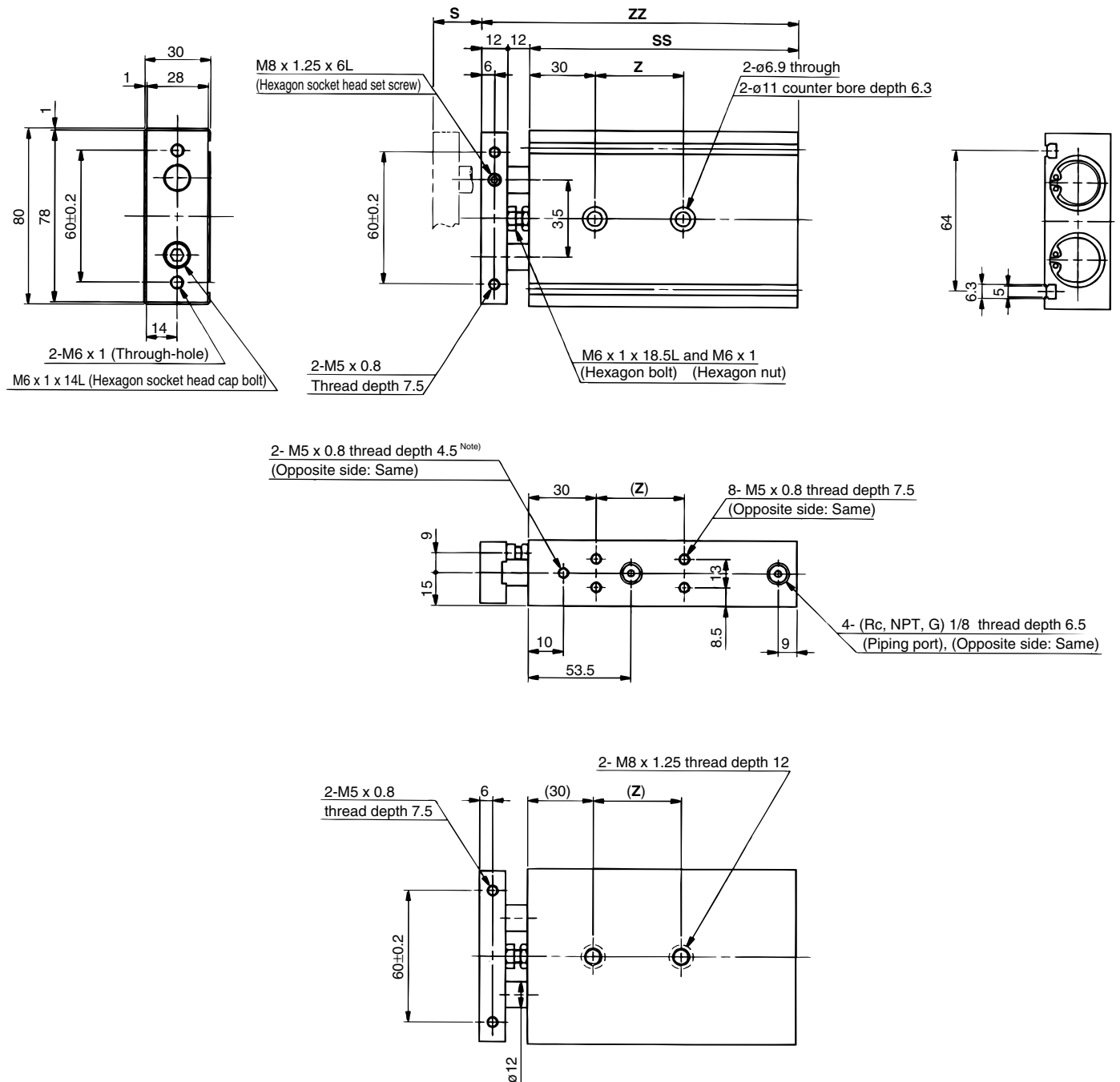

Note) 11-, 22- : Vacuum suction port Vacuum air from 2 ports on both sides. 10-/12-, 21- : Exhaust port Exhaust air from a port on one side. The port on the piston rod B side for 10-/12-, 21- is plugged since unlike the vacuum, it is not necessary to exhaust from 2 ports.

Model	S	SS	ZZ	Z
^{10-/11-} _{21-/22-} CXS □ 25-10	10	94	118	30
^{10-/11-} _{21-/22-} CXS □ 25-20	20	104	128	40
^{10-/11-} _{21-/22-} CXS □ 25-30	30	114	138	40
^{10-/11-} _{21-/22-} CXS □ 25-40	40	124	148	40
^{10-/11-} _{21-/22-} CXS □ 25-50	50	134	158	60
^{10-/11-} _{21-/22-} CXS □ 25-75	75	159	183	60
^{10-/11-} _{21-/22-} CXS □ 25-100	100	184	208	80

Basic style / ^{10-/11-}₂₂₋**CXS** □ **32**, ¹²⁻₂₁₋**CXSL** **32**

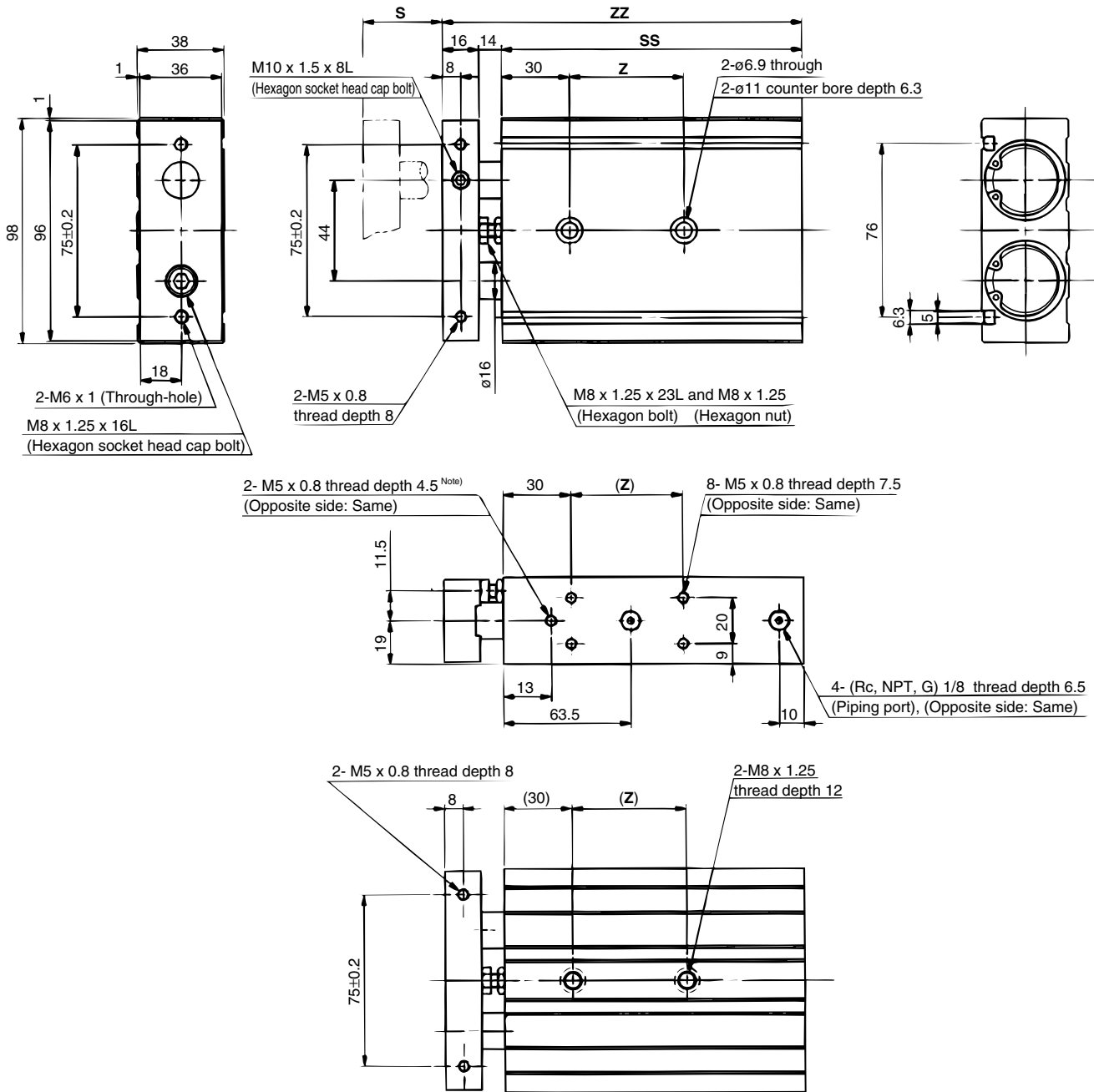

Note) 11-, 22- : Vacuum suction port Vacuum air from 2 ports on both sides. 10-/12-, 21- : Exhaust port Exhaust air from a port on one side. The port on the piston rod B side for 10-/12-, 21- is plugged since unlike the vacuum, it is not necessary to exhaust from 2 ports.

Model	S	SS	ZZ	Z
^{10-/11-} _{21-/22-} CXS □ 32-10	10	104	134	40
^{10-/11-} _{21-/22-} CXS □ 32-20	20	114	144	50
^{10-/11-} _{21-/22-} CXS □ 32-30	30	124	154	50
^{10-/11-} _{21-/22-} CXS □ 32-40	40	134	164	50
^{10-/11-} _{21-/22-} CXS □ 32-50	50	144	174	60
^{10-/11-} _{21-/22-} CXS □ 32-75	75	169	199	70
^{10-/11-} _{21-/22-} CXS □ 32-100	100	194	224	90



Specific product precautions

Be sure to read before handling.

Mounting

⚠ Caution

- 1. Make sure that the surface on which the cylinder is to be mounted is flat (reference value for flatness : 0.05 or less).**
Dual rod cylinders can be mounted from 3 directions, however, make sure that the surface on which the cylinder is to be mounted is flat (reference value for flatness: 0.05 or less). Otherwise, the accuracy of the piston rod operation is not achieved, and malfunction may occur.
- 2. The piston rod must be retracted when mounting the cylinder.**
Scratches or gouges in the piston rod may lead to damaged bearings and seals, and causes malfunction or air leakage.
- 3. Secure the plate before mounting the load.**
Load mounting without securing the plate may cause galling of the piston rod, leading to particle generation.

Piping

⚠ Caution

- 1. Plug the appropriate supply port(s) according to the operating conditions.**
Dual rod cylinders have 2 supply ports for each operating direction (3 supply ports for ø6 only). Plug the appropriate supply port according to the operating conditions. After the plugged port has been changed, check the port for air leakage. If small leakage is detected, unplug the port, check the seat surface, and reassemble it.
- 2. For 12- relief port, change the plug position according to the operating conditions.**
A relief port is provided on each side. Change the plug position according to the operating conditions. After the change, apply 0.1 MPa pressure from the relief port to check the plugged portion for air leakage. If small leakage is detected, unplug the port, check the seat surface, and reassemble it.
- 3. Vacuum air from vacuum ports on both sides of 11- and 22-.**
Vacuum from one side is insufficient. Be sure to vacuum simultaneously from both sides.

Stroke Adjustment

⚠ Caution

- 1. After adjusting the stroke, tighten firmly the hexagon nut to prevent it from loosening.**
Dual rod cylinders have a bolt to adjust 0 to - 5 strokes on the retracted end (IN).
Loosen the hexagon nut to adjust the stroke. However, make sure to tighten the hexagon nut after making an adjustment.
- 2. Do not operate a cylinder with its bumper bolt removed.**
If the bumper bolt is removed, the piston hits the head cover, causing damage to the cylinder. Therefore, do not use a cylinder without a bumper bolt.
- 3. A bumper at the end of the bumper bolt is replaceable. In case a missing bumper, or a bumper has a permanent setting, use the following part numbers for ordering.**

Model	CXS6/10/15	CXS20/25	CXS32
Part number	CXS10-34A 28747	CXS20-34A 28749	CXS32-34A 28751
No. of bumpers	1		

Disassembly and Maintenance

⚠ Caution

- 1. Never use a cylinder with its plate removed.**
When removing the hexagon socket head cap screw from the end plate, the piston rod must be secured to prevent rotation. However, if the sliding parts of the piston rod are scratched or gouged, malfunction may occur. If a plate is not required for your applications, use the cylinder that does not come with a plate, available through Made to Order (-X593).
- 2. When disassembling and reassembling the cylinder, contact SMC or refer to the separate instruction manual.**

⚠ Warning

- 1. Take precautions when your hands are near the plate and housing.**
During cylinder operation, be careful not to get your hand or fingers caught between the plate and housing.